

A-A (1:1)

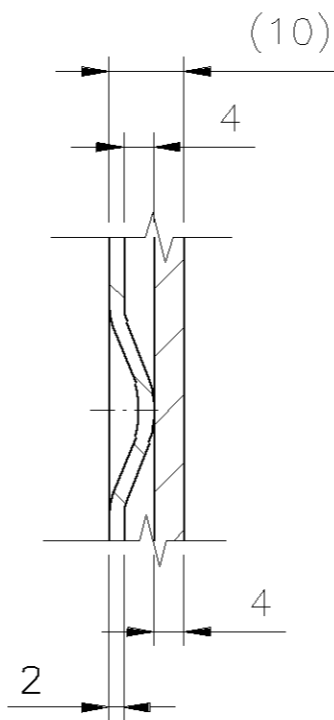

Z (1:1)

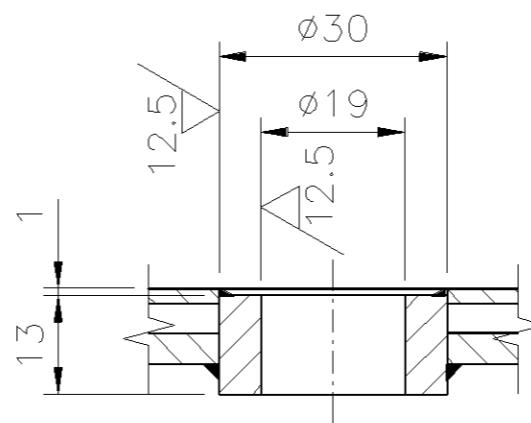

B-B

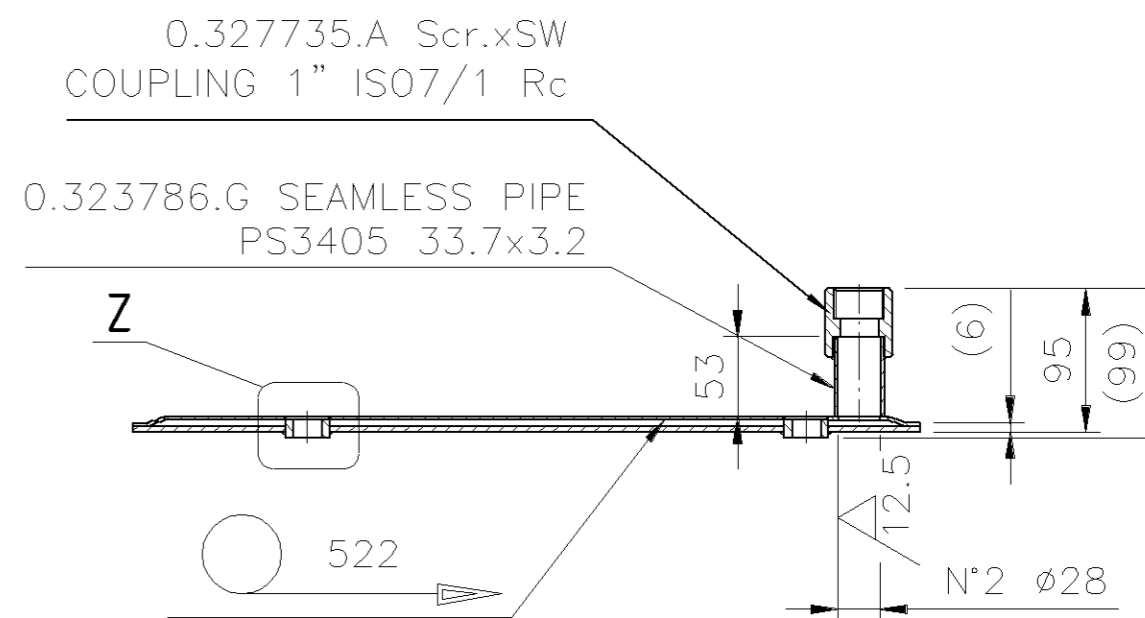

FORNITORE: TERMOTECH O EQUIVALENTE
 SUPPLIER: THERMOTECH OR EQUAL

NOTE: INTERNAL WELDING DESIGN TO BE
 HANDLED BY THE SUPPLIER

- FLUIDO UTILIZZATO / FLUID USED : ACQUA / WATER
 - PRESSIONE DI ESERCIZIO / WORKING PRESSURE : 0.5 MPa
 - PRESSIONE DI COLLAUDO / TEST PRESSURE : 0.75 MPa
 PER / FOR : 2 ORE / HOURS.

TUTTE LE SALDATURE DEVONO ESSERE A TENUTA DI ACQUA
 E DI CLASSE B SECONDO STD DANIELI 2.8.006
 ALL WELDINGS MUST BE WATER TIGHT AND CLASS B
 ACCORDING TO DANIELI STD 2.8.006

SALDATURE A NORMA DANIELI
 STD 2.8.006 CLASSE B
 WELDS AS PER DANIELI
 STD 2.8.006 CLASS ...

DOVE NON INDICATO A = 0.7 DELLO
 SPESSORE MINIMO DA COLLEGARE
 WHERE NOT INDICATED A = 0.7 OF
 MINIMUM THICKNESS TO BE WELDED

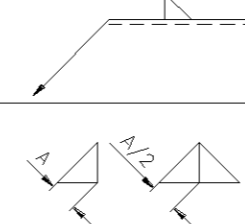

Rev.	Date	Revisions description	Drawn by	Checked by	Approved by
00	27 Oct 2008	EMESSO PER COSTRUZIONE ISSUED FOR CONSTRUCTION	Burchak	Marchenk	Sandrin
Material 1 (where not indicated on drawing) X5CrNi18-10 EN 10088-2			State of supply Mat.1	Danieli Supply Std.	Supply Class Pattern DB
Material 2 SEE DRAWING As per D&C Dwg			State of supply Mat.2	Danieli Supply Std.	Supply Class Casting Code
Material 3			State of supply Mat.3	Danieli Supply Std.	Supply Class

Heat Treatment DISTENSIONE A MEZZO VIBRAZIONI
 On Drawing Symbol, if required, VIBRATORY STRESS RELIEVING
 Coating
 On Drawing Symbol, if required,

Unquoted radius (mm)	Unquoted bevels (mm)	Dimensions without tolerance as per	Machinings	Max. Welding Class
		DANIELI STD 2.4.103	0 [12.5/✓✓✓✓✓✓✓✓✓✓]	B

Project Name

	Job nr	
	Obtained from	5.308265.X
	Replaces	
Family code/Machine code	43600	
Weight (Kg)	42	J (Kgm ²)

Title		SCAMBIATORE DI CALORE HEAT EXCHANGER		
DANIELI Shop number		5.339098.B		
DANIELI dwg number		Revision	00	Scale
		Revision		Format
				Nr. of sheets
				001
				Sheet
				001 Follow

According to law DANIELI & C. SpA considers this document to be a company secret and therefore prohibits any person to reproduce or disclose it or make it known in whole or in part to other parties or to competitors without specific written authorization of DANIELI's Management