

## CARR LOCK® CLAMPS



**FEATURES:** The Carr Lock® System allows accurately locating and clamping at the same time, with just the turn of a hex wrench. Ideal for mounting quick-change tooling on a subplate. Each mount consists of three components: (1) a Carr Lock® Clamp, with a precisely ground shank; (2) a Liner Bushing in the top plate; (3) a Receiver Bushing in the subplate. This compact assembly provides considerable holddown force, together with an incredible  $\pm 0.0005$ " repeatability! Made in USA.

**SIZES:** Available in the following shank diameters — see Dimensions page for part numbers:

13mm  
16mm  
20mm  
25mm  
30mm  
35mm  
50mm

Each shank diameter is available in a choice of lengths for different top plate thicknesses (both inch and metric). Thick top plates can be counterbored to use shorter clamps.

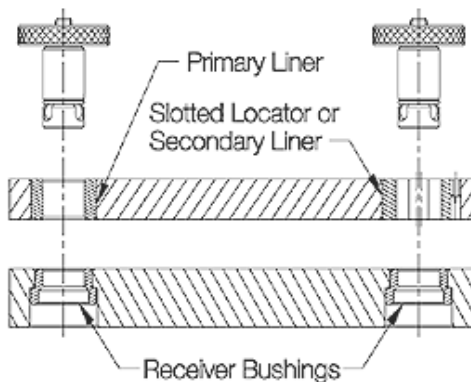

**OPERATION:** Turning the clamping screw with a hex wrench advances the large center ball, pushing the three clamping balls outward. These balls engage the angled ID section of the Receiver Bushing, pulling the clamp firmly downward. Clamps with 16mm and 20mm shank diameter are optionally available with a Knurled Head Screw for actuation.

### DESIGN CONSIDERATIONS & SAFETY

**PRECAUTIONS:** Carr Lock® Clamps should only be used to locate and clamp flat plates on machine tools. Each top plate should have one Carr Lock® mount designated as its primary reference point, and one as its secondary reference point. These two mounts should be as far apart as possible. The secondary reference point should have a relieved liner to avoid redundant location (binding). Additional Carr Lock® Clamps can be used for more clamping force, but these should be installed in clearance holes, not locating liners. Note that the same Carr Lock® Clamp fits into any type of liner or a clearance hole. Carr Lock® Clamps must be used with Carr Lock® Receiver Bushings for proper operation. Plate thickness must be  $\pm 0.005$ " to achieve full clamping force. Do not exceed maximum screw torque shown.

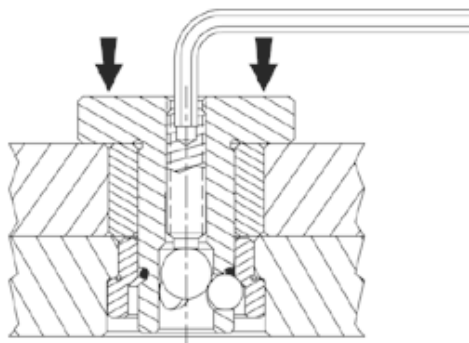

Turning the clamping screw advances the large center ball, pushing the three clamping balls outward to engage the receiver bushing.

**MATERIAL:** Clamp body > 4340 steel, heat treated Rc 40-45. Balls > 440C stainless. Clamping screw > Carbon steel, black oxide finish. O-ring > Viton. DFARS and RoHS compliant.

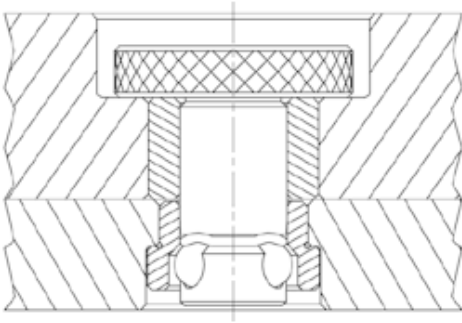

Extra-thick top plates can be counterbored to achieve proper clamping thickness (hold thickness to  $\pm.005$ ").



en\_252